



REFERENCIA CAFTE	REFERENCIA ETS	Plano	Hoja	Total	NOMBRE DEL PLANO		
					Línea 1	Línea 2	Línea 3
TTE-IS-23003-SE-AN9-0	3-SEUDC-23-001-A	0	01	FIN	INDICE DE PLANOS		
TTE-IS-23003-SE-AN9-1.1	3-SEUDC-23-002-A	1.1	01	FIN	DETALLES CONSTRUCTIVOS	SEÑAL FERROVIARIA LEDs	SEÑAL ALTA 4 FOCOS CON PILOTO BLANCO
TTE-IS-23003-SE-AN9-1.2	3-SEUDC-23-003-A	1.2	02	FIN	DETALLES CONSTRUCTIVOS	SEÑAL FERROVIARIA LEDs	CABEZA SEÑAL ALTA 2 FOCOS
TTE-IS-23003-SE-AN9-1.3	3-SEUDC-23-004-A	1.3	03	FIN	DETALLES CONSTRUCTIVOS	SEÑAL FERROVIARIA LEDs	SEÑALES DE MANIOBRA
TTE-IS-23003-SE-AN9-2.1	3-SEUDC-23-005-A	2.1	01	FIN	DETALLES CONSTRUCTIVOS	ATP	EUROLOOP (I)
TTE-IS-23003-SE-AN9-2.2	3-SEUDC-23-006-A	2.2	02	FIN	DETALLES CONSTRUCTIVOS	ATP	EUROLOOP (II)
TTE-IS-23003-SE-AN9-3.1	3-SEUDC-23-007-A	3.1	01	FIN	DETALLES CONSTRUCTIVOS	ELEMENTOS AUXILIARES	CAJA TERMINALES. VISTA SUPERIOR. CAJA 100 BORNAS
TTE-IS-23003-SE-AN9-3.2	3-SEUDC-23-008-A	3.2	02	FIN	DETALLES CONSTRUCTIVOS	ELEMENTOS AUXILIARES	CAJA TERMINALES. CUERPO INFERIOR. CAJA 100 BORNAS
TTE-IS-23003-SE-AN9-3.3	3-SEUDC-23-009-A	3.3	03	FIN	DETALLES CONSTRUCTIVOS	ELEMENTOS AUXILIARES	PEDESTAL CAJA. HASTA 50 Y 100 BORNAS
TTE-IS-23003-SE-AN9-3.4	3-SEUDC-23-010-A	3.4	04	FIN	DETALLES CONSTRUCTIVOS	ELEMENTOS AUXILIARES	SECCIÓN TIPO. CRUCE BAJO VÍAS
TTE-IS-23003-SE-AN9-3.5	3-SEUDC-23-011-A	3.5	05	FIN	DETALLES CONSTRUCTIVOS	ELEMENTOS AUXILIARES	DETALLES ARQUETAS (I)
TTE-IS-23003-SE-AN9-3.6	3-SEUDC-23-012-A	3.6	06	FIN	DETALLES CONSTRUCTIVOS	ELEMENTOS AUXILIARES	DETALLES ARQUETAS (II)

REV.	CLASE DE MODIFICACION	FECHA	NOMBRE	COMP.	OBRA
A	PRIMERA EMISIÓN	FEB.24	IOS	ETS	
BERRIKUSPENAK / REVISIONES					
AHOLKULARIA / CONSULTOR			INGENIARI EGILEA INGENIERO AUTOR		
			 Ibañeta Saezma Colegiado N° 12.732		
AHOLKULARIAREN ERREFERENTZIA REFERENCIA CONSULTOR			ERREFERENTZIA REFERENCIA		
TTE-IS-23003-SE-AN9-0			3-SEUDC-23-001-A		



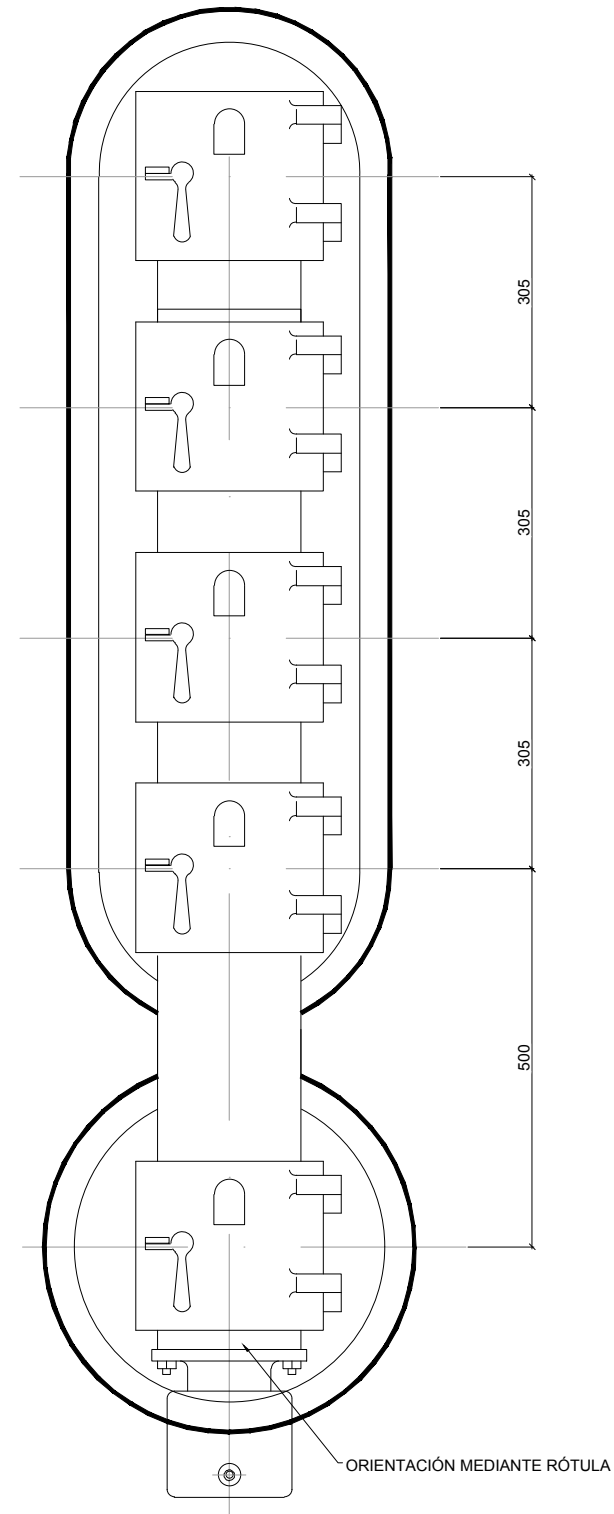
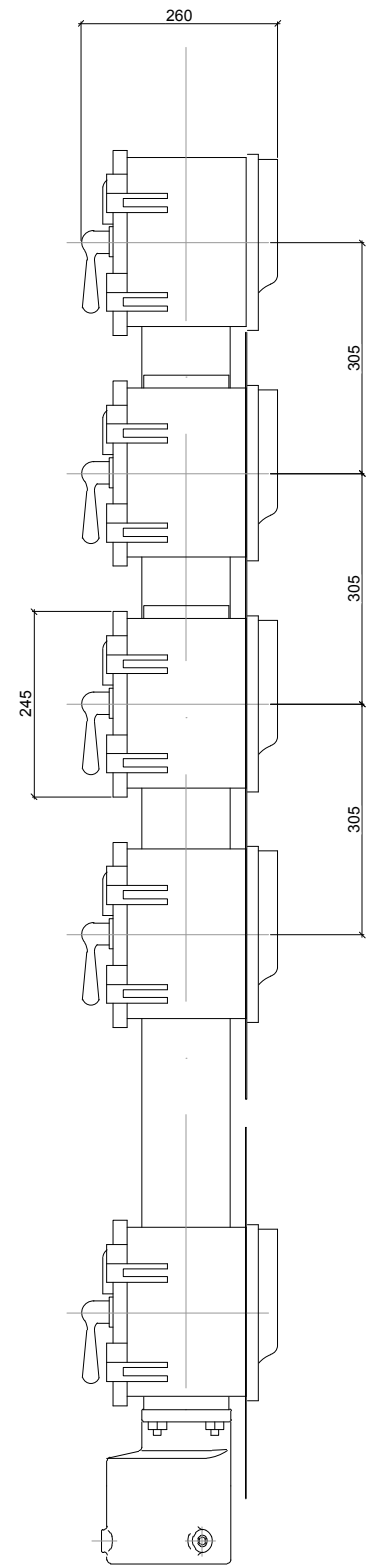
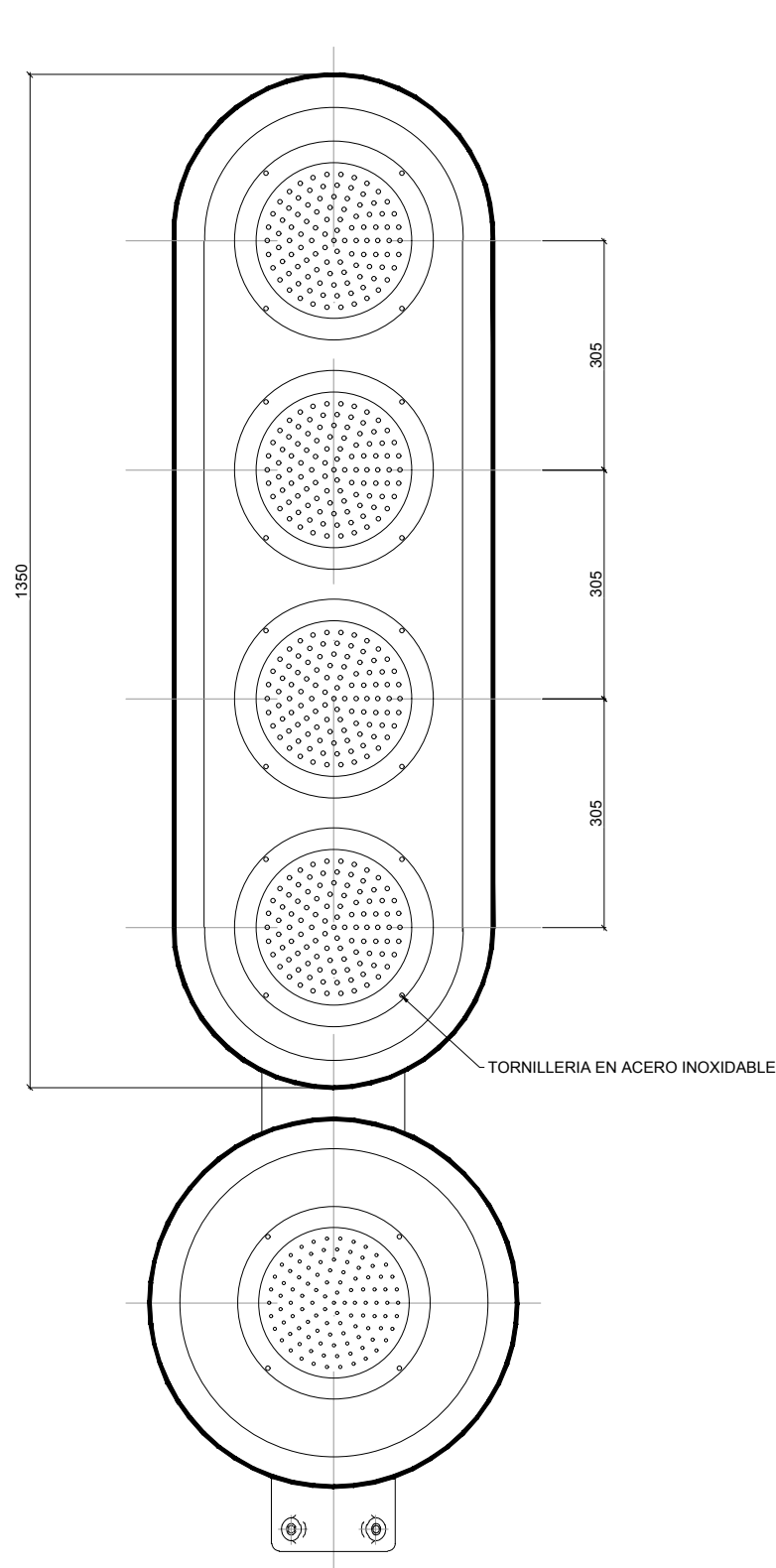

A	PRIMERA EMISIÓN	FEB.24	IOS	ETS	
REV.	CLASE DE MODIFICACION	FECHA	NOMBRE	COMP.	OBRA
BERRIKUSPENAK / REVISIONES					
AHOLKULARIA / CONSULTOR		INGENIARI EGILEA INGENIERO AUTOR			
<b>CAF</b> TURNKEY ENGINEERING		Ibañeta Saezma Colegiado N° 12.732			
AHOLKULARIAREN ERREFERENTZIA REFERENCIA CONSULTOR		ERREFERENTZIA REFERENCIA			
TTE-IS-23003-SE-AN9-1.1		3-SEUDC-23-002-A			

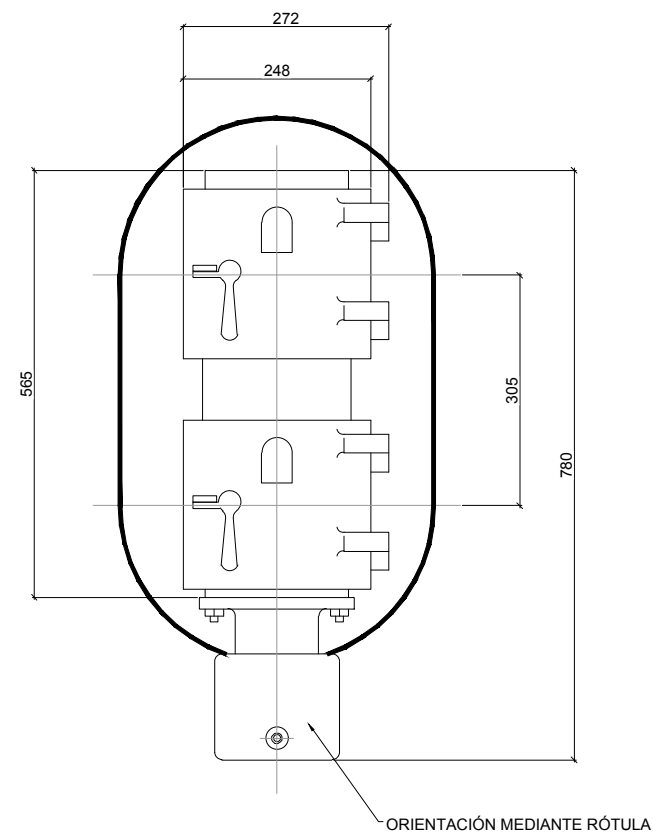
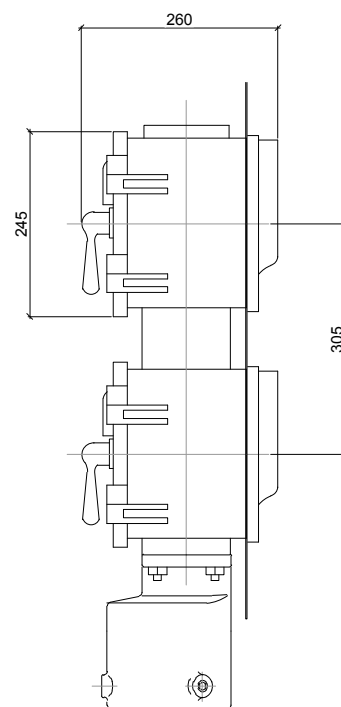
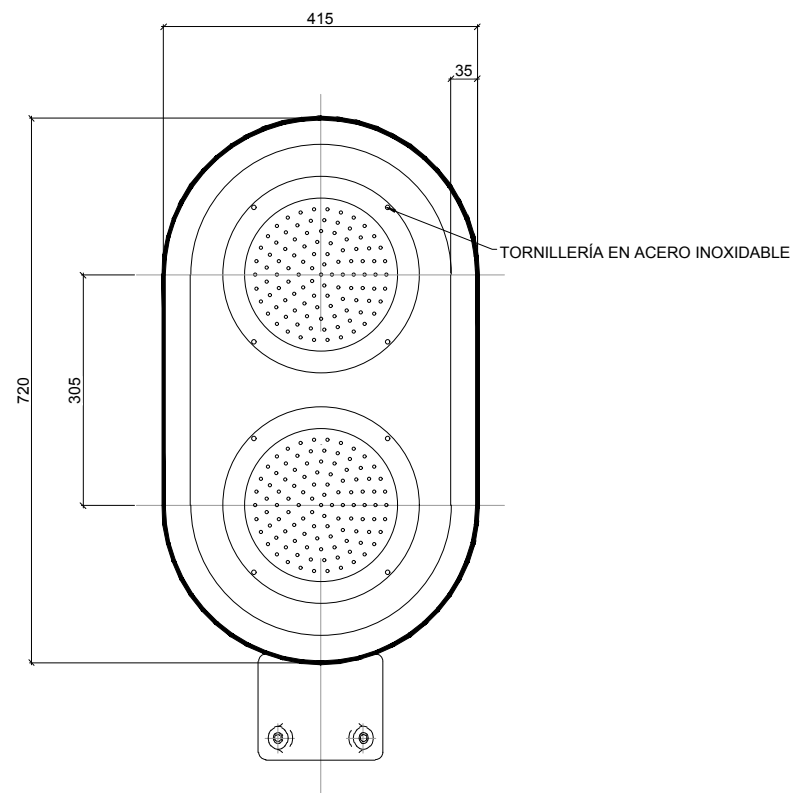

A	PRIMERA EMISIÓN	FEB.24	IOS	ETS	
REV.	CLASE DE MODIFICACION	FECHA	NOMBRE	COMP.	OBRA
BERRIKUSPENAK / REVISIONES					
AHOLKULARIA / CONSULTOR			INGENIARI EGILEA INGENIERO AUTOR		
			 Ibañeta Saezma Colegiado N° 12.732		
AHOLKULARIAREN ERREFERENTZIA REFERENCIA CONSULTOR			ERREFERENTZIA REFERENCIA		
TTE-IS-23003-SE-AN9-1.2			3-SEUDC-23-003-A		

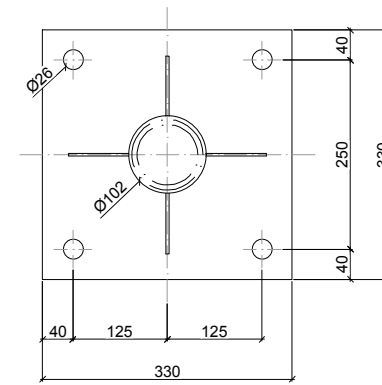
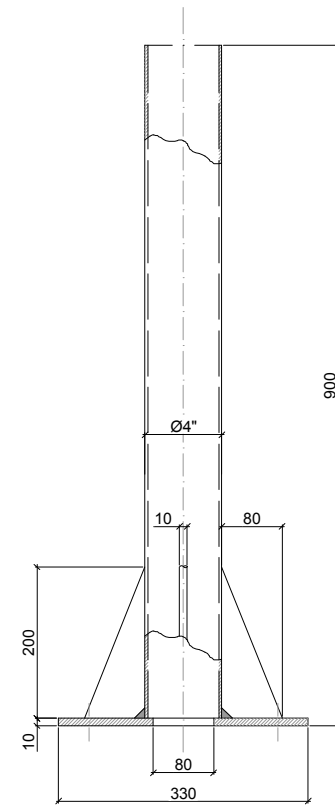
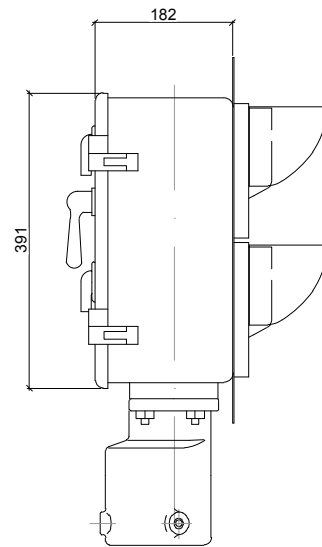
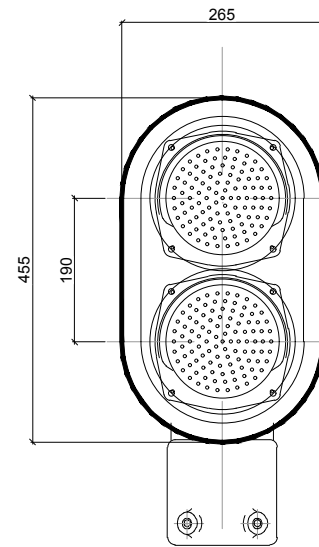

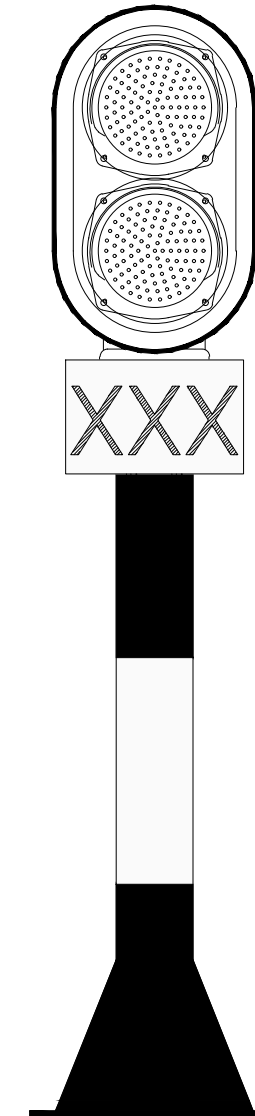

DETALLE COLUMNA

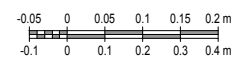

A	PRIMERA EMISIÓN	FEB.24	IOS	ETS	
REV.	CLASE DE MODIFICACION	FECHA	NOMBRE	COMP.	OBRA
BERRIKUSPENAK / REVISIONES					
AHOLKULARIA / CONSULTOR			INGENIARI EGILEA INGENIERO AUTOR		
			 Ibañeta Saezma Colegiado N° 12.732		
AHOLKULARIAREN ERREFERENTZIA REFERENCIA CONSULTOR			ERREFERENTZIA REFERENCIA		
TTE-IS-23003-SE-AN9-1.3			3-SEUDC-23-004-A		

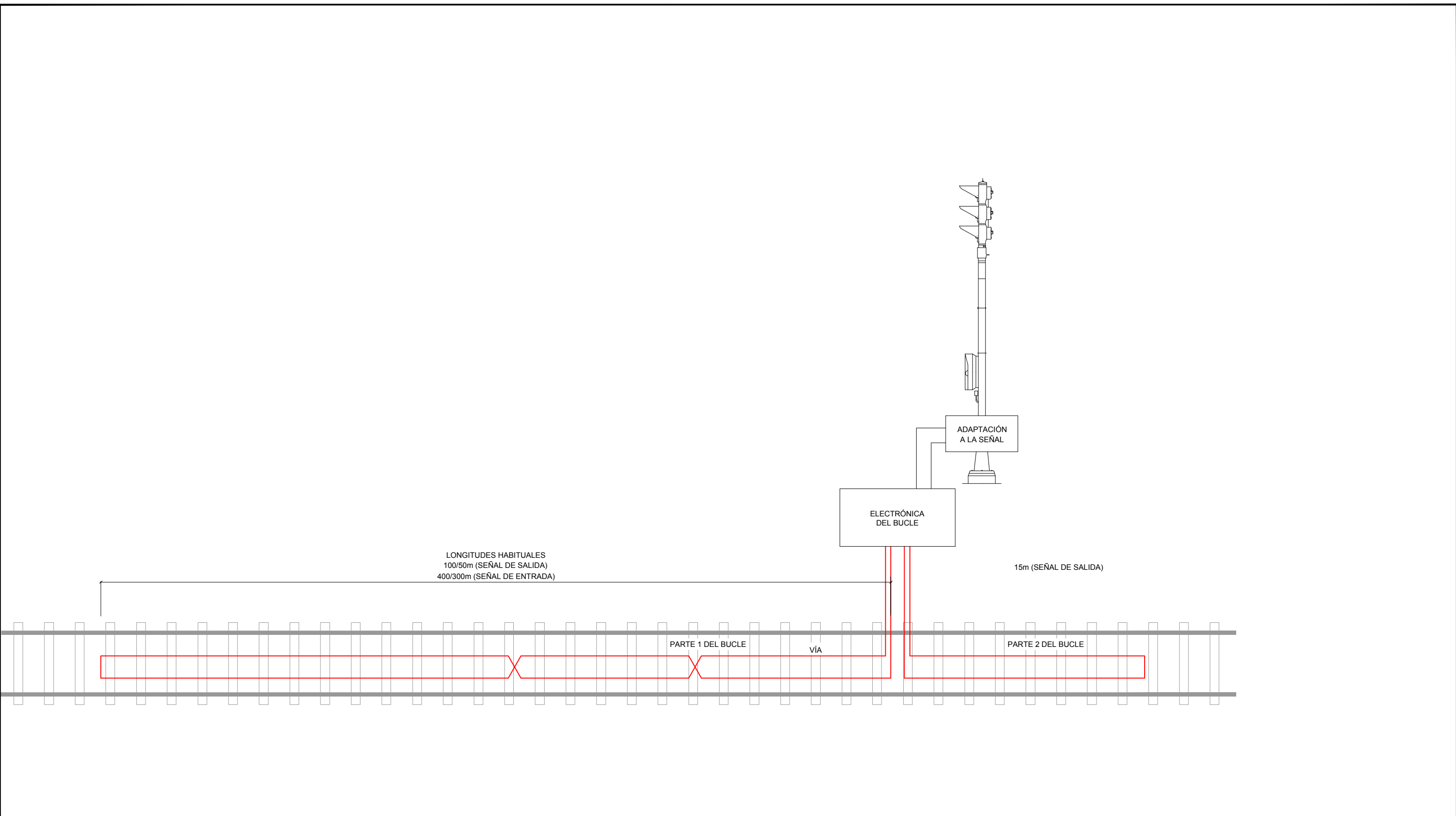

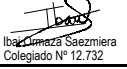

REV.	A	PRIMERA EMISIÓN	FEB.24	IOS	ETS
		CLASE DE MODIFICACION	FECHA	NOMBRE	COMP. OBRA
BERRIKUSPENAK / REVISIONES					
AHOLKULARIA / CONSULTOR			INGENIARI EGILEA INGENIERO AUTOR		
 <b>TURNKEY ENGINEERING</b>			 Ibañeta Saezma Colegiado N° 12.732		
AHOLKULARIAREN ERREFERENTZIA REFERENCIA CONSULTOR			ERREFERENTZIA REFERENCIA		
TTE-IS-23003-SE-AN9-2.1			3-SEUDC-23-005-A		

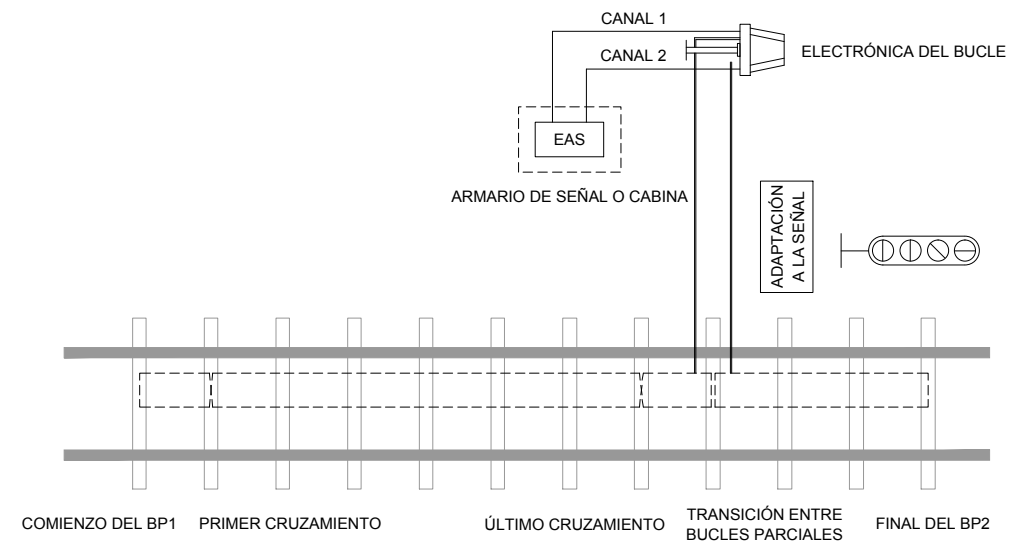

REV.	PRIMERA EMISIÓN	FEB.24	IOS	ETS	
	CLASE DE MODIFICACION	FECHA	NOMBRE	COMP.	OBRA
BERRIKUSPENAK / REVISIONES					
AHOLKULARIA / CONSULTOR			INGENIARI EGILEA INGENIERO AUTOR		
			 Ibañeta Saezma Colegiado N° 12.732		
AHOLKULARIAREN ERREFERENTZIA REFERENCIA CONSULTOR			ERREFERENTZIA REFERENCIA		
TTE-IS-23003-SE-AN9-2.2			3-SEUDC-23-006-A		

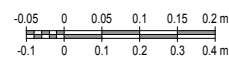

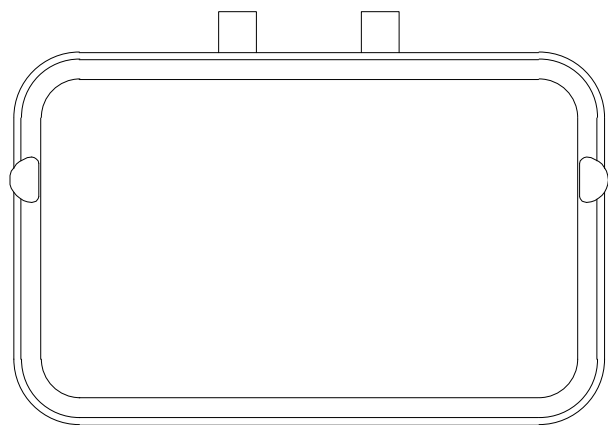

VISTA SUPERIOR

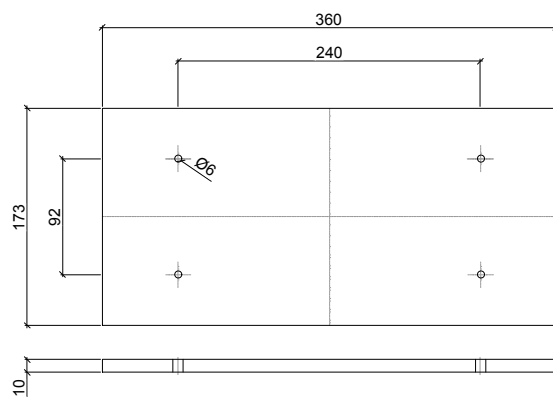

PESCAGOTAS

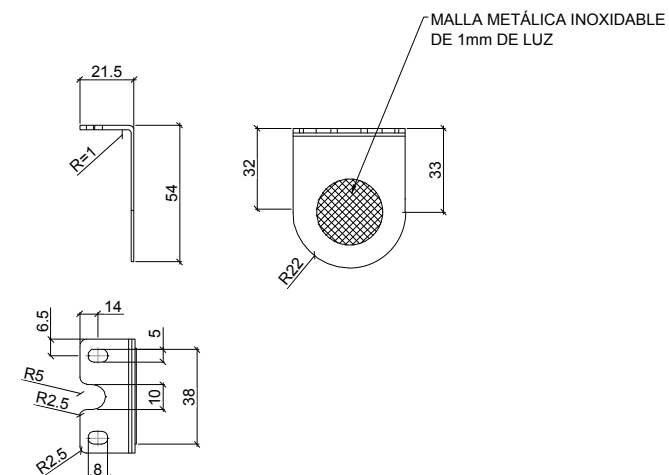

ESCUADRA CON MALLA METÁLICA PARA RESPIRADERO  
CHAPA INOXIDABLE DE 1,5mm DE ESPESOR  
2 UNIDADES

DETALLE RESPIRADERO

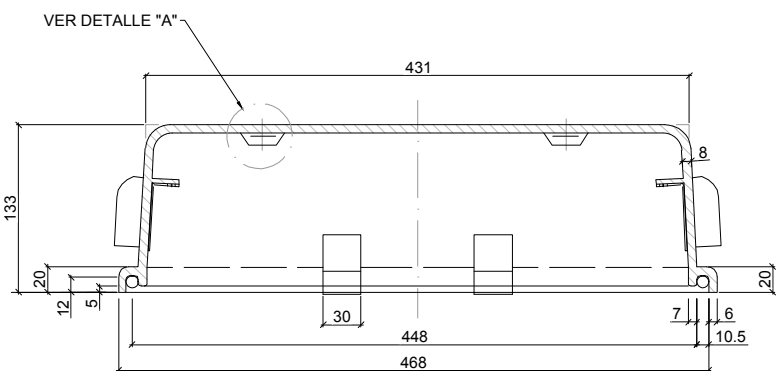

SECCIÓN A-A

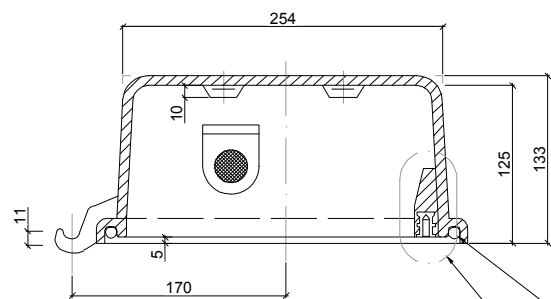

SECCIÓN B-B

JUNTA TÓRICA EN TODO EL PERFIL

VER DETALLE "B"

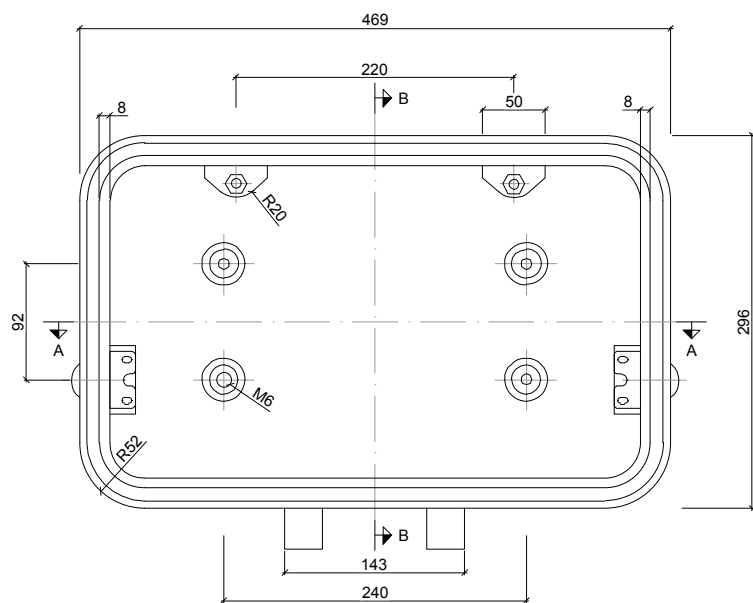

VISTA INFERIOR



DETALLE A

DETALLE B

REV.	A	PRIMERA EMISIÓN	FEB.24	IOS	ETS
		CLASE DE MODIFICACION	FECHA	NOMBRE	COMP. OBRA
BERRIKUSPENAK / REVISIONES					
AHOLKULARIA / CONSULTOR			INGENIARI EGILEA INGENIERO AUTOR		
AHOLKULARIAREN ERREFERENTZIA REFERENCIA CONSULTOR			ERREFERENTZIA REFERENCIA		
TTE-IS-23003-SE-AN9-3.1			3-SEUDC-23-007-A		

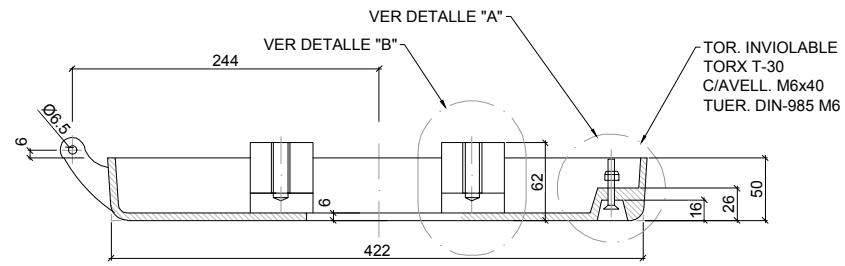

SECCIÓN A-A

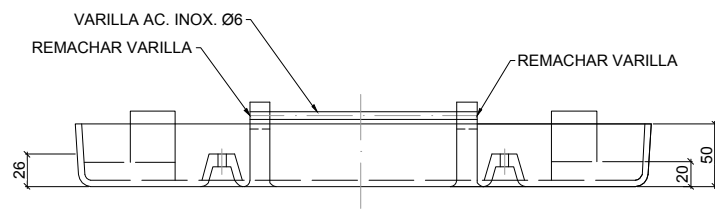

VISTA POSTERIOR

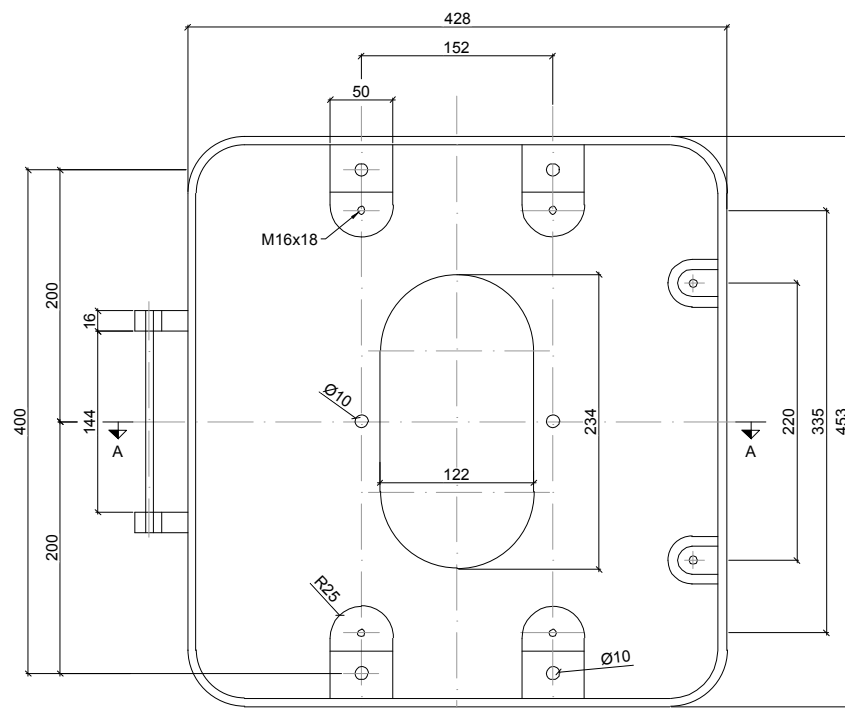
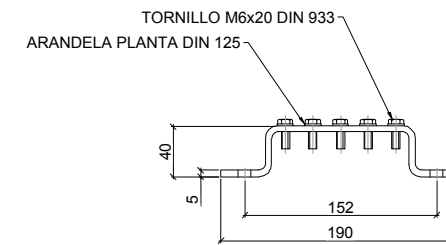

VISTA SUPERIOR

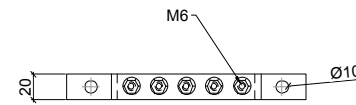

PLETINA DE TIERRA

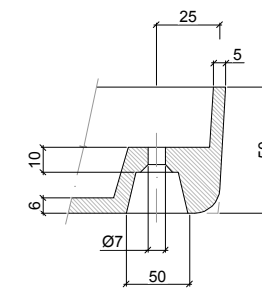

DETALLE "A"

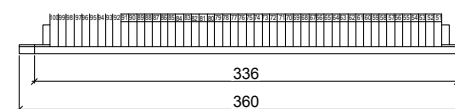
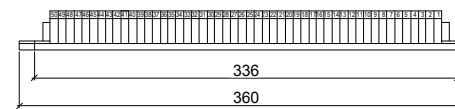

NOTA: MONTAR 2 REGLETAS, UNA CON NUMERACIÓN 1 A 50 Y OTRA CON NUMERACIÓN 51 A 100.

REGLETERO

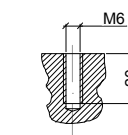

DETALLE "B"

REV.	CLASE DE MODIFICACION	FECHA	IOS	ETS	OBRA
A	PRIMERA EMISIÓN	FEB.24	IOS	ETS	
BERRIKUSPENAK / REVISIONES					
AHOLKULARIA / CONSULTOR			INGENIARI EGILEA INGENIERO AUTOR		
AHOLKULARIAREN ERREFERENTZIA REFERENCIA CONSULTOR			ERREFERENTZIA REFERENCIA		
TTE-IS-23003-SE-AN9-3.2			3-SEUDC-23-008-A		



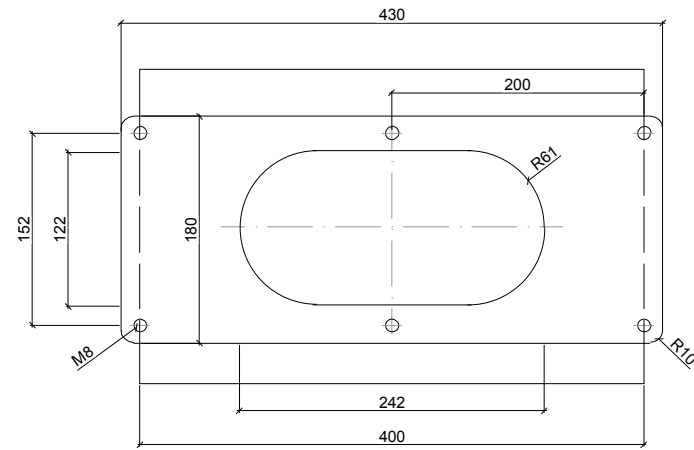

PLANCHA SUPERIOR

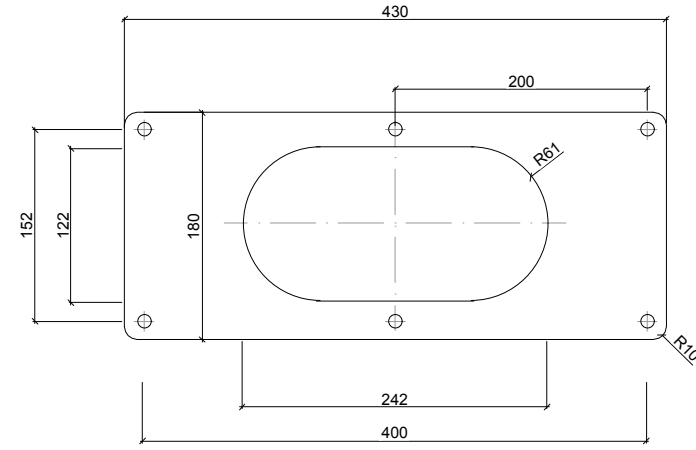

JUNTA DE NEOPRENO

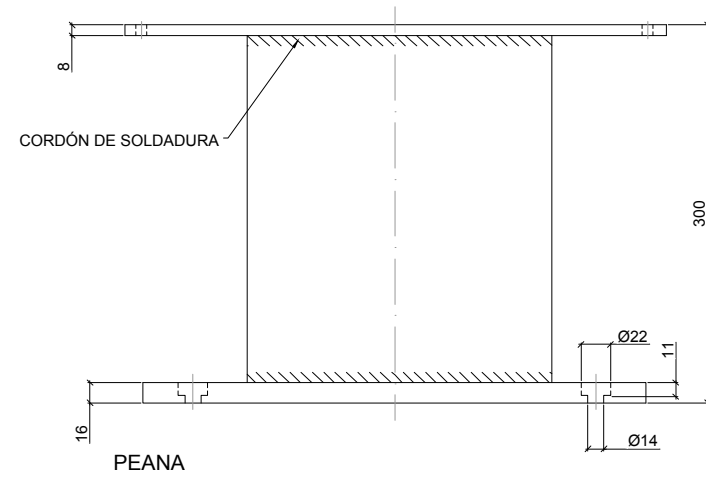

PEANA

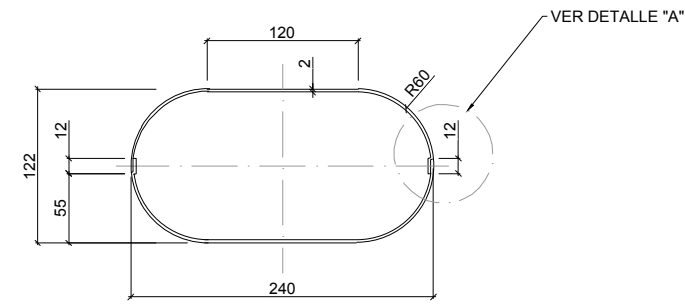

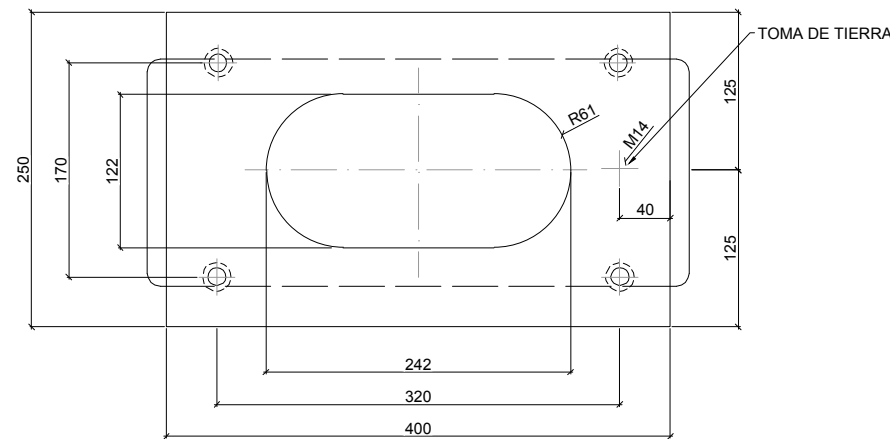

DETALLE TUBO PEANA

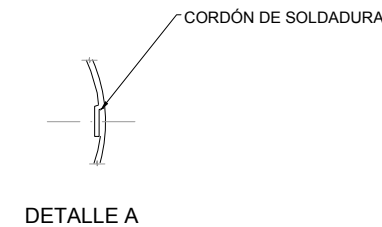

TOMA DE TIERRA



DETALLE A

REV.	CLASE DE MODIFICACION	FECHA	NOMBRE	COMP.	OBRA
A	PRIMERA EMISIÓN	FEB.24	IOS	ETS	
BERRIKUSPENAK / REVISIONES					
AHOLKULARIA / CONSULTOR			INGENIARI EGILEA INGENIERO AUTOR		
 <b>TURNKEY ENGINEERING</b>			 Ibañeta Saezma Colegiado N° 12.732		
AHOLKULARIAREN ERREFERENTZIA REFERENCIA CONSULTOR			ERREFERENTZIA REFERENCIA		
TTE-IS-23003-SE-AN9-3.3			3-SEUDC-23-009-A		

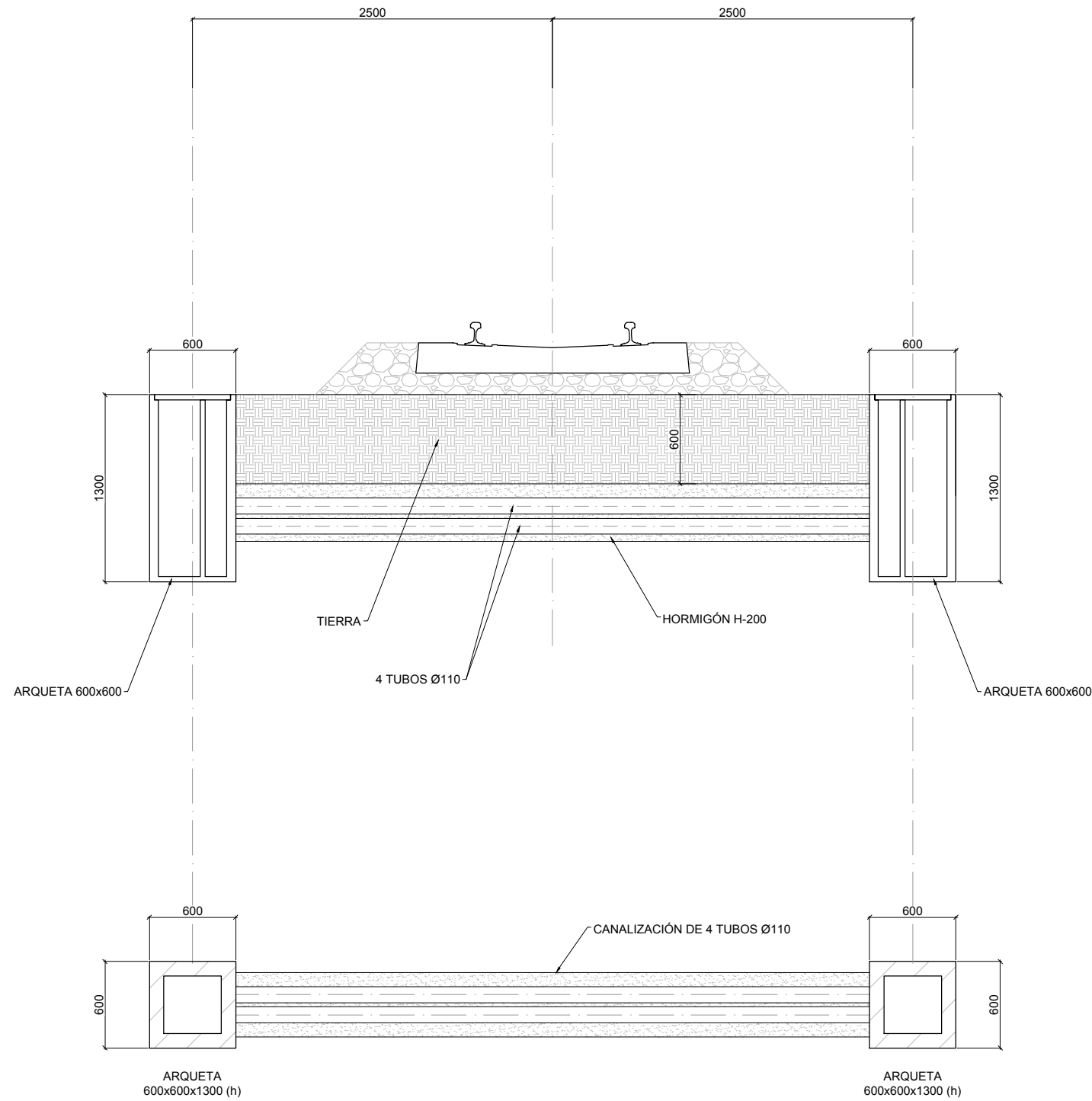

A	PRIMERA EMISIÓN	FEB.24	IOS	ETS	
REV.	CLASE DE MODIFICACION	FECHA	NOMBRE	COMP.	OBRA
BERRIKUSPENAK / REVISIONES					
AHOLKULARIA / CONSULTOR			INGENIARI EGILEA INGENIERO AUTOR		
			 Ibañeta Saezma Colegiado N° 12.732		
AHOLKULARIAREN ERREFERENTZIA REFERENCIA CONSULTOR			ERREFERENTZIA REFERENCIA		
TTE-IS-23003-SE-AN9-3.4			3-SEUDC-23-010-A		

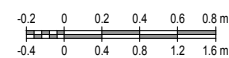

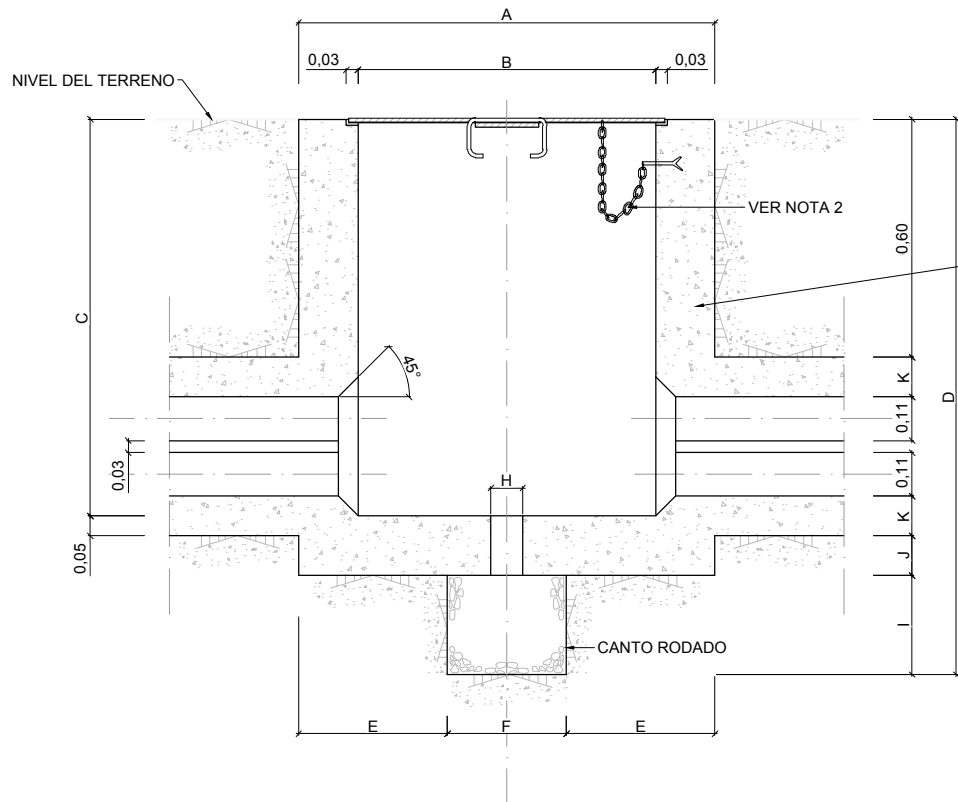

SECCIÓN LONGITUDINAL

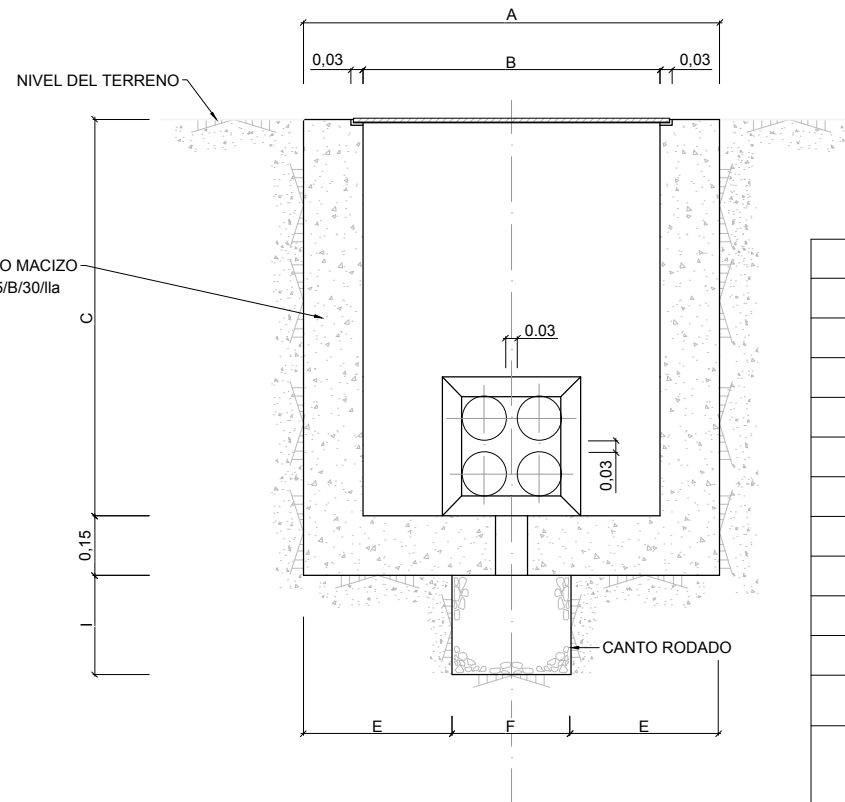

SECCIÓN TRANSVERSAL

A	640	1050	1200
B	400	750	900
C	860	1000	1140
D	1130	1400	1540
E	220	375	400
F	200	300	400
G	452	802	952
H	70	80	80
I	150	250	250
J	120	100	100
K	80	100	100
	PEQUEÑA	MEDIANA	GRANDE
DIMENSIONES PARA DISTINTOS TIPOS DE ARQUETAS			

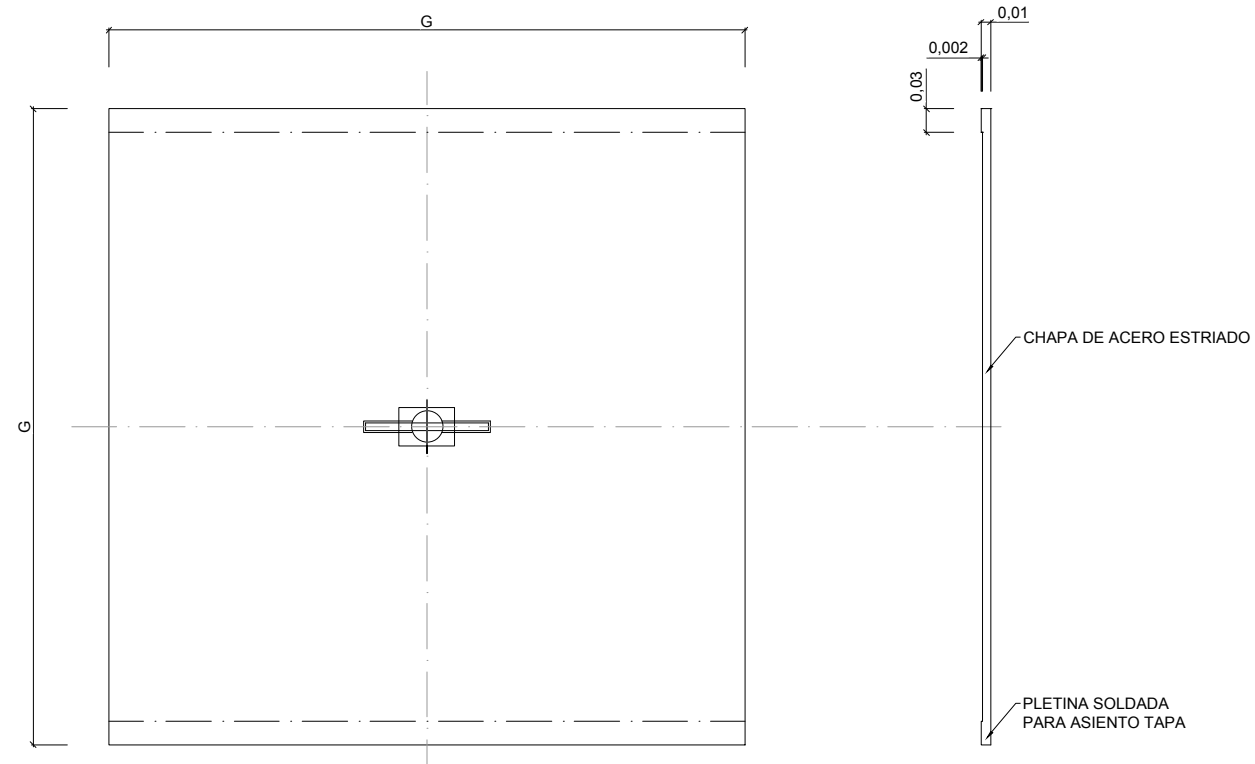
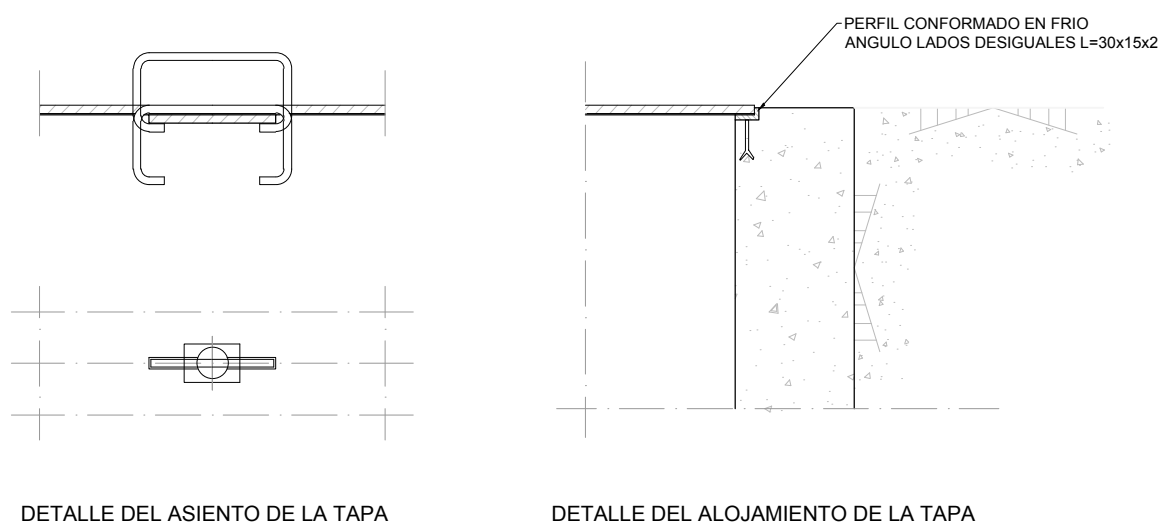

A	PRIMERA EMISIÓN	FEB.24	IOS	ETS	
REV.	CLASE DE MODIFICACION	FECHA	NOMBRE	COMP.	OBRA
BERRIKUSPENAK / REVISIONES					
AHOLKULARIA / CONSULTOR			INGENIARI EGILEA INGENIERO AUTOR		
<b>CAF</b> TURNKEY ENGINEERING			<i>IOS</i> Ibañeta Saezma Colegiado Nº 12.732		
AHOLKULARIAREN ERREFERENTZIA REFERENCIA CONSULTOR			ERREFERENTZIA REFERENCIA		
TTE-IS-23003-SE-AN9-3.5			3-SEUDC-23-011-A		

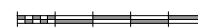

ARQUETA TIPO 1

ARQUETA TIPO 2

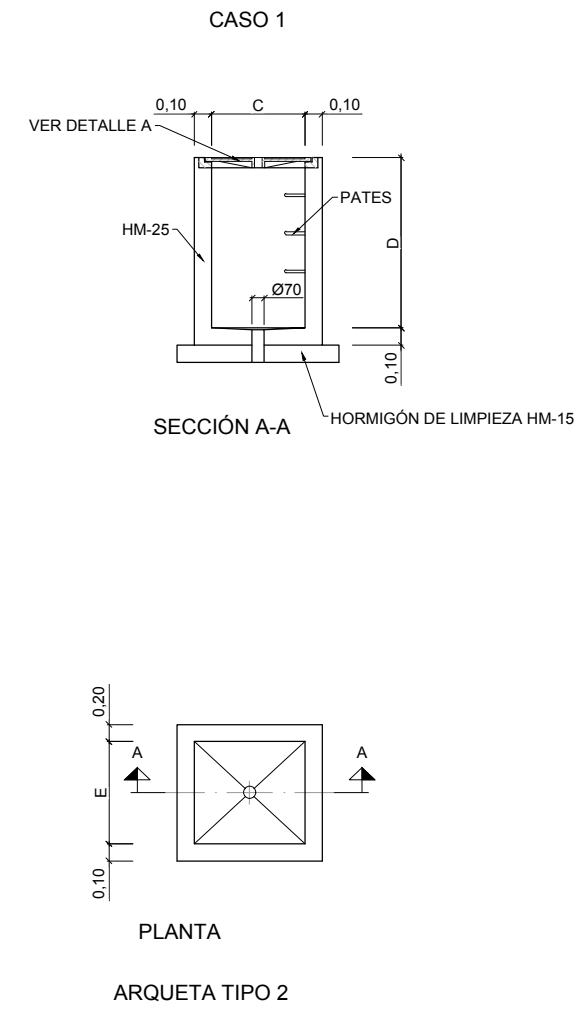
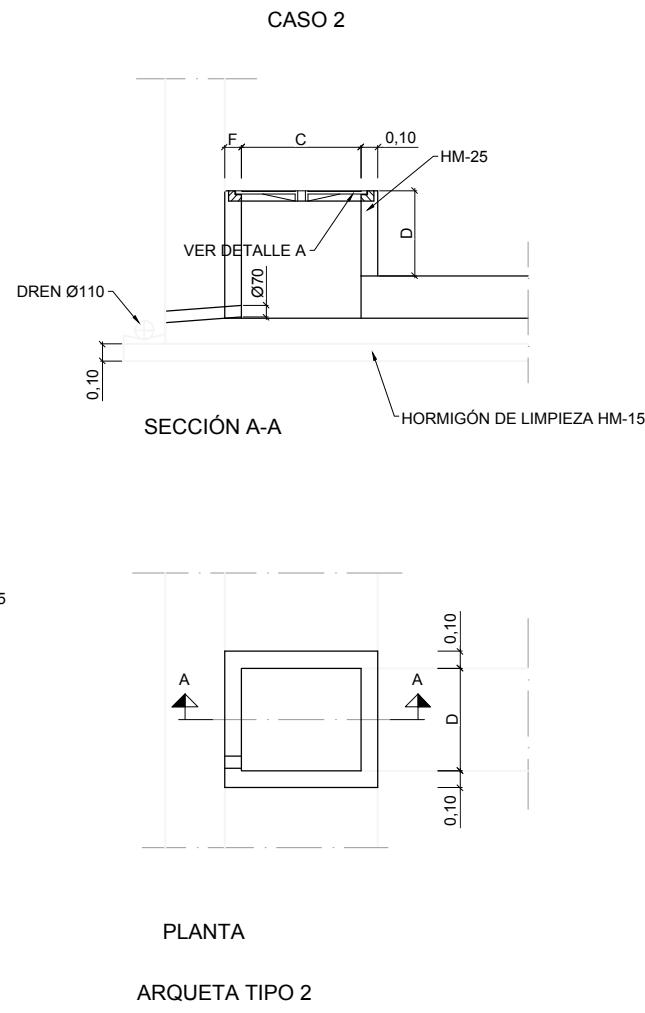
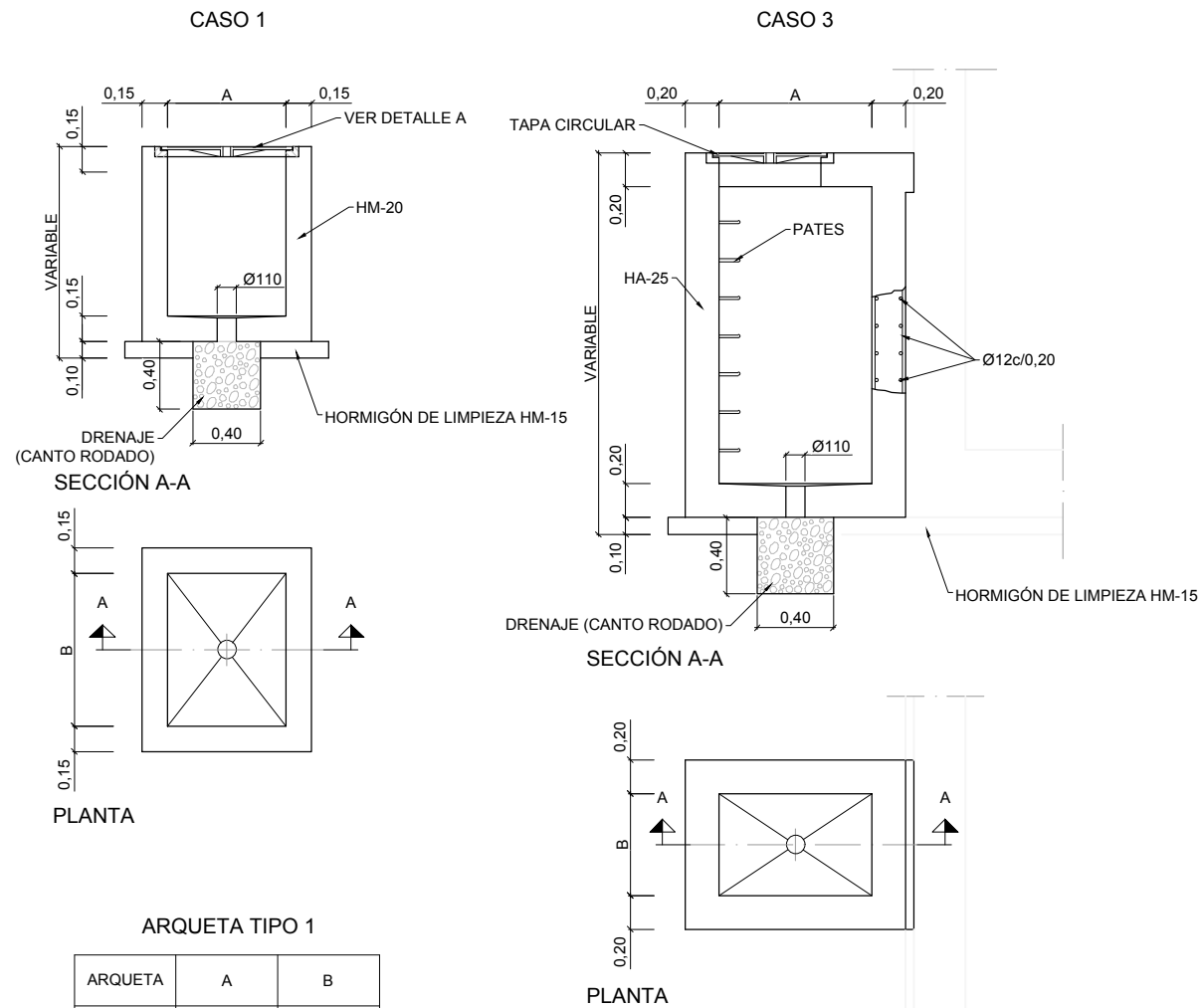

ARQUETA TIPO 1

ARQUETA	A	B
m.	m.	m.
PEQUEÑA	0,30	0,60
MEDIANA	0,70	0,90
GRANDE	0,90	0,90

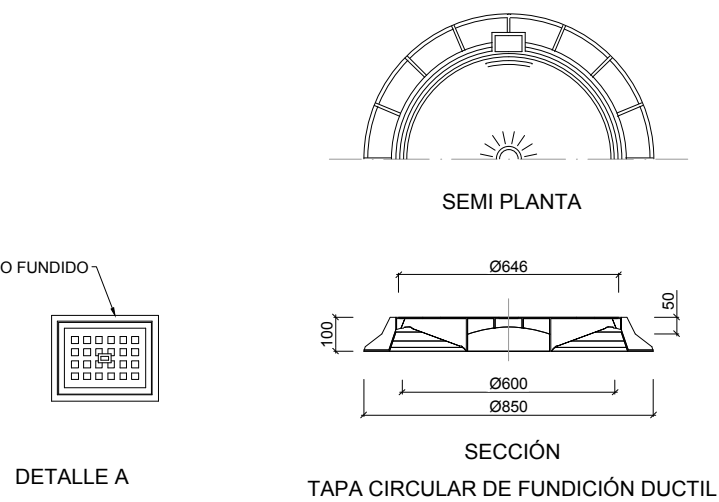
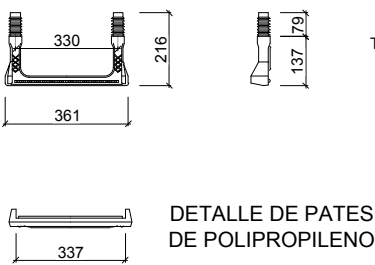

ARQUETA TIPO 2

ARQUETA CANALIZACIÓN	C	D	E	F
m.	m.	m.	m.	m.
A-1	0,50	0,40	0,60	0,10
A-2	0,65	0,40	0,60	0,10
B	0,20	0,30	0,60	0,10
C	0,45	0,30	0,60	0,05
D	0,65	0,40	0,60	0,10
E	0,55	0,70	0,60	0,10

NOTA:

CASO 1: CANALIZACIÓN EN BALASTO.  
CASO 2: CANALIZACIÓN EN INTRADOS DEL MURO  
CASO 3: CANALIZACIÓN EN TRASDOS DEL MURO  
TIPO 1: ARQUETAS EXTERIORES  
TIPO 2: ARQUETAS INTERIORES

CARACTERÍSTICAS DE LOS MATERIALES Y COEFICIENTES DE SEGURIDAD			
		CONTROL DE MATERIALES Y COEFICIENTE DE SEGURIDAD	
HORMIGÓN	DE LIMPIEZA	fck > 15N/mm <sup>2</sup>	REDUCIDO
	ARMADO	fck > 25N/mm <sup>2</sup>	NORMAL Vc = 1,5
	EN MASA	fck > 20N/mm <sup>2</sup>	NORMAL Vc = 1,5
ACERO	EN MASA	fck > 25N/mm <sup>2</sup>	NORMAL Vc = 1,5
	CORRUGADO (Ø)	fy > 500N/mm <sup>2</sup>	NORMAL Vs = 1,15
CONTROL DE EJECUCIÓN	NORMAL	COEFICIENTE DE MAYORACIÓN DE ACCIONES	Vf = 1,6

REV.	CLASE DE MODIFICACION	FECHA	IOS	ETS	OBRA
A	PRIMERA EMISIÓN	FEB.24	IOS	ETS	

BERRIKUSPENAK / REVISIONES

AHOLKULARIA / CONSULTOR	INGENIARI EGILEA INGENIERO AUTOR
<b>CAF</b> TURNKEY ENGINEERING	<i>[Signature]</i> Ibañeta Saezma Colegiado N° 12.732
AHOLKULARIAREN ERREFERENTZIA REFERENCIA CONSULTOR	ERREFERENTZIA REFERENCIA
TTE-IS-23003-SE-AN9-3.6	3-SEUDC-23-012-A

