

OHARRAK:
NOTAS:

Poner letrero indicativo que existe tensión proveniente de un SAI en estos circuitos.
Para Operaciones de mantenimiento abrir el interruptor Q1-4, o Q-405 en el Cuadro de SAI del CGBT.

ALIMENTADO DESDE SAI (1)

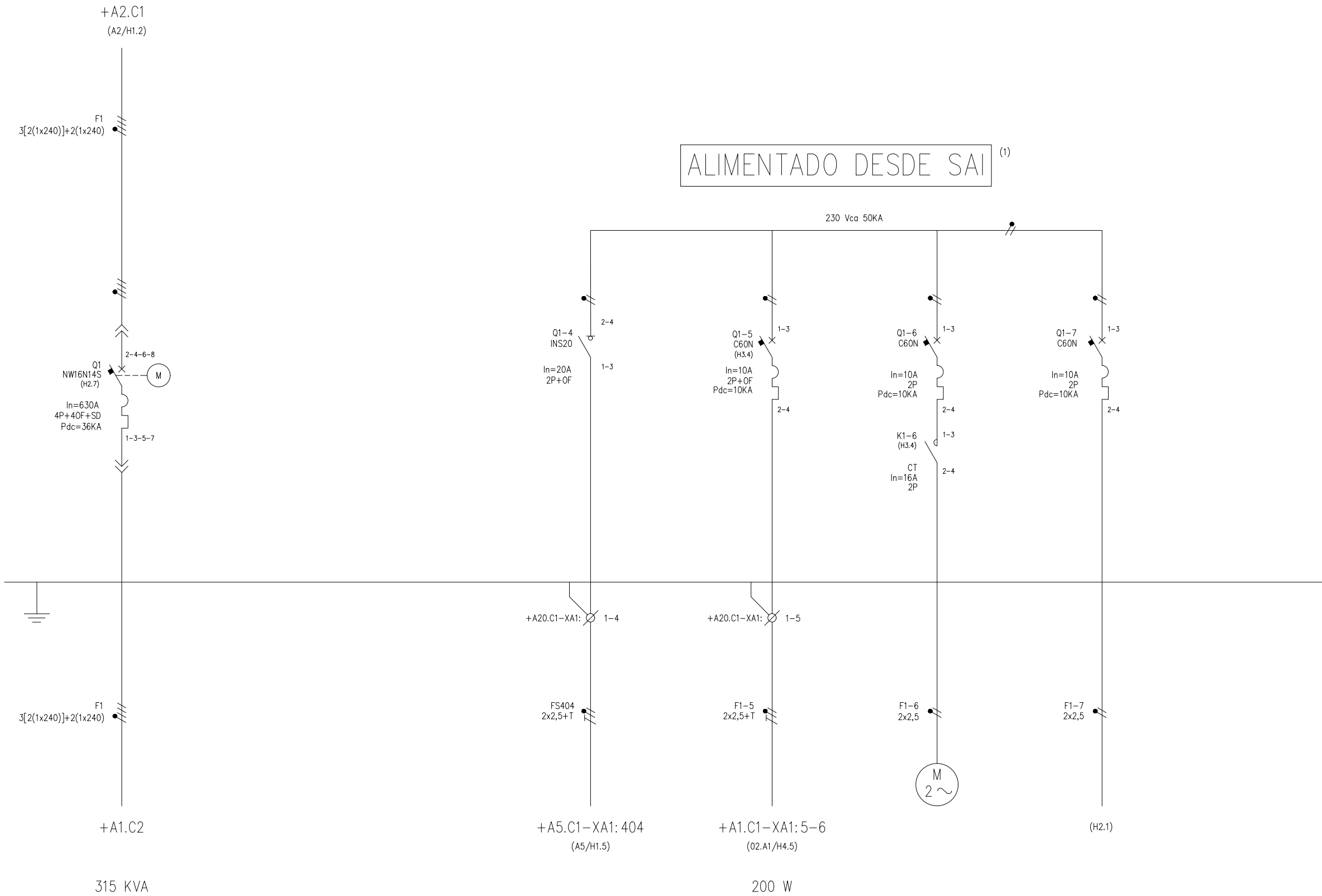

REV.	CLASE DE MODIFICACION	FECHA	NOMBRE	COMP.	OBRA
A	PRIMERA EMISION	MAR. 23	IAA	ETS	

BERRIKUSPENAK / REVISIONES

ALIMENTACIÓN CUADRO DESDE TRAF0 T1	ALIMENTACIÓN MANIOBRA Y OTROS SERVICIOS DESDE SAI	ALIMENTACIÓN RELÉ FALTAS HOMOPOLARES 13.2 kV	VENTILADOR CUADRO	ALIMENTACIÓN CONTROL MANIOBRA DE INTERRUPTOR Q1
------------------------------------	---------------------------------------------------	----------------------------------------------	-------------------	-------------------------------------------------

+A20.C1 - CUADRO CSBT

AHOLKULARIA / CONSULTOR	INGENIARI EGILEA INGENIERO AUTOR
AHOLKULARIAREN ERREFERENTZIA REFERENCIA CONSULTOR	ERREFERENTZIA REFERENCIA
TTE-IS-23001-DRW-0150	2RVA-IE-22-150-A

OHARRAK :
NOTAS :
* PUENTEADO EN BORNERO

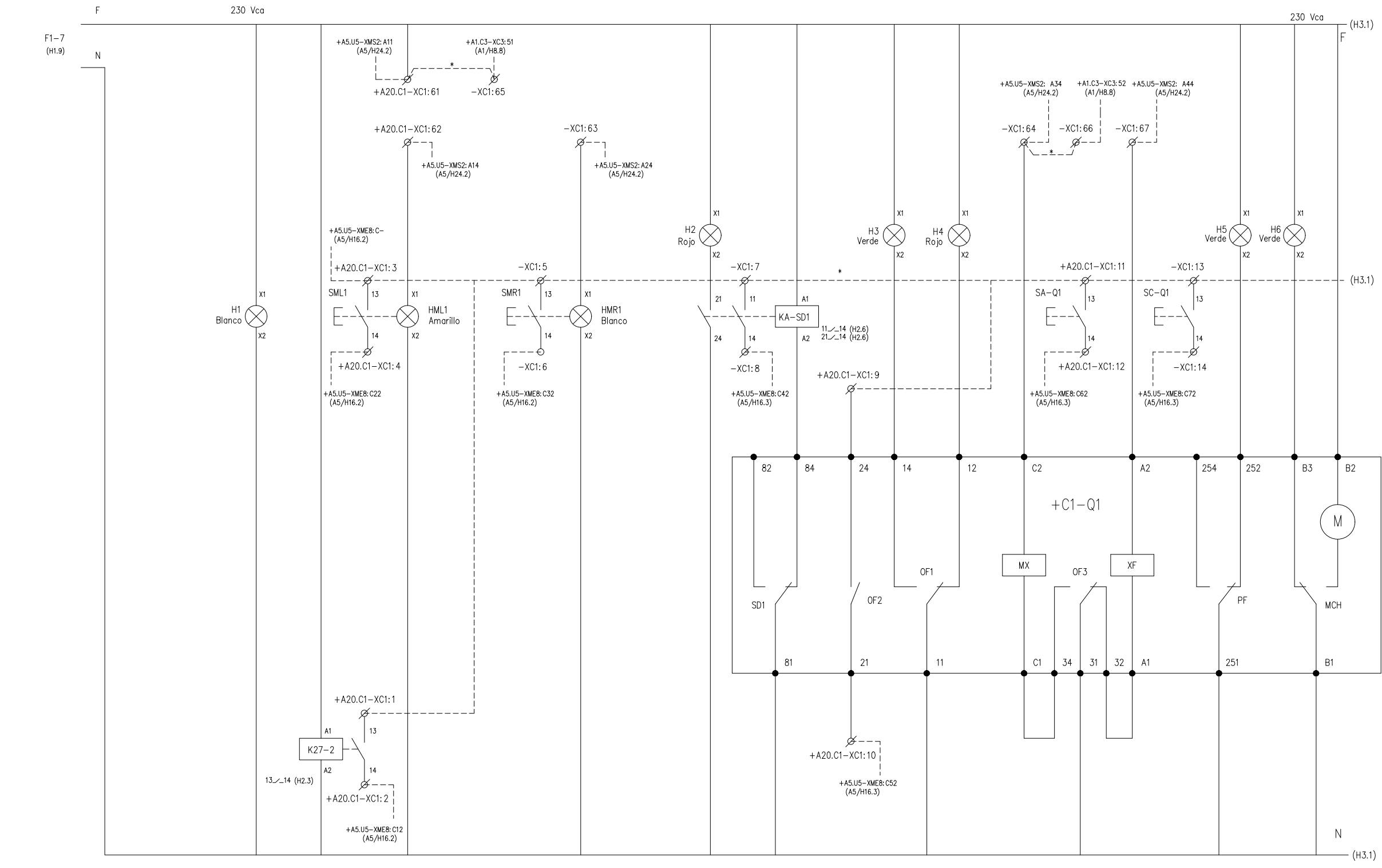

Alimentación Circuito Control Presencia Tensión Mando Local Mando Remoto Disparo Interruptor Q1 Interruptor Cerrado Interruptor Abierto Apertura Interruptor Cierre Interruptor Listo para Cerrar Armado

+A20.C1 ACOMETIDA TRAF0 N°1
+A20.C1 - CUADRO CSBT

REV.	PRIMERA EMISION	MAR. 23	IAA	ETS
REV.	CLASE DE MODIFICACION	FECHA	NOMBRE	COMP. OBRA
BERRIKUSPENAK / REVISIONES				
AHOLKULARIA / CONSULTOR		INGENIARI EGILEA INGENIERO AUTOR		
AHOLKULARIAREN ERREFERENTZIA REFERENCIA CONSULTOR		ERREFERENTZIA REFERENCIA		
TTE-IS-23001-DRW-0151		2RVA-IE-22-151-A		

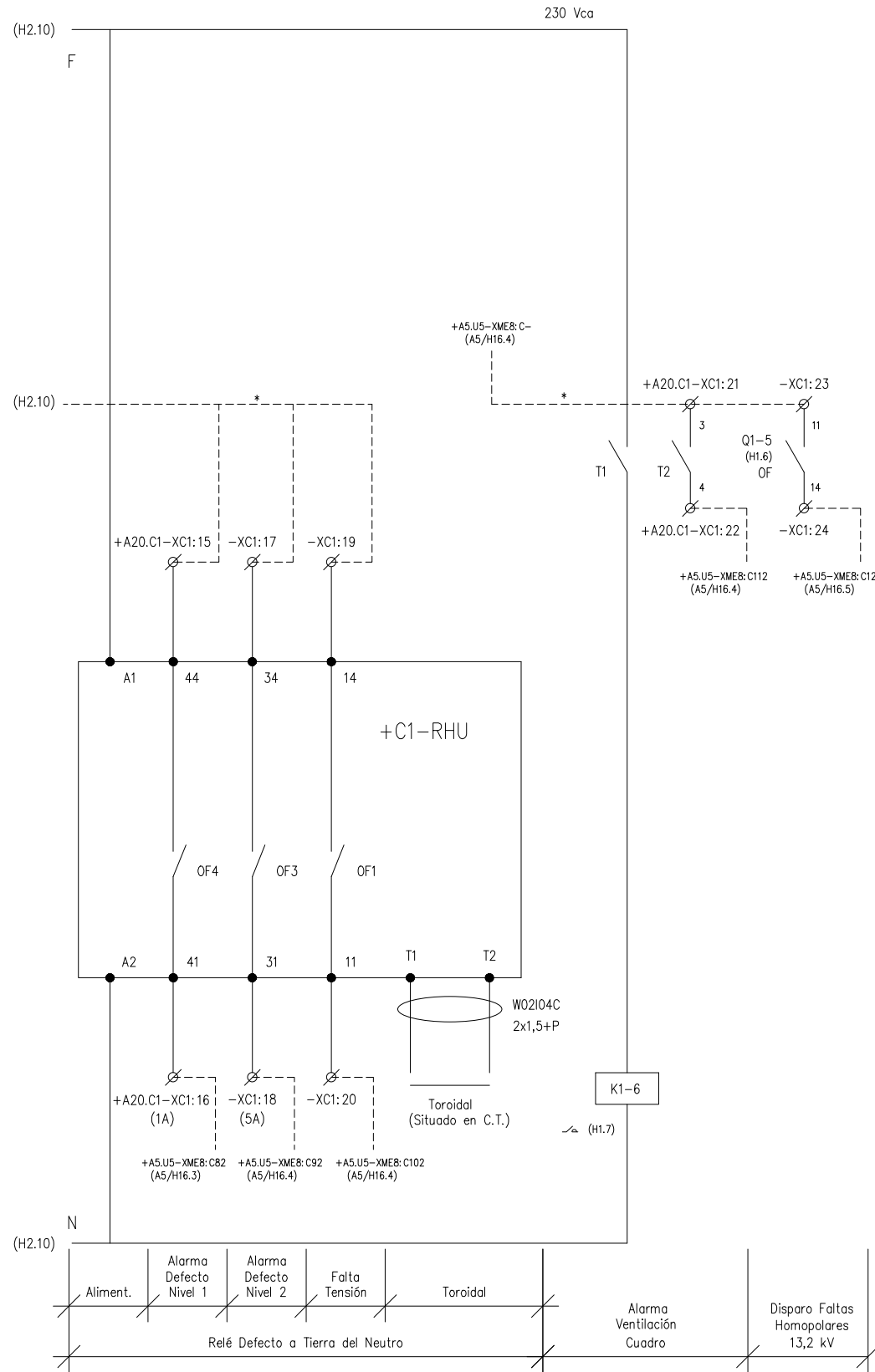

OHARRAK:
 NOTAS:
 El termostato interior del cuadro tendra 2 contactos libres, T1 temperatura de funcionamiento y T2 temperatura de alarma.
 * PUENTEADO EN BORNERO

+A20.C1 ACOMETIDA TRAF0 N°1



+A20.C1 - CUADRO CSBT

REV.	CLASE DE MODIFICACION	FECHA	NOMBRE	COMP.	OBRA
A	PRIMERA EMISION	MAR. 23	IAA	ETS	
BERRIKUSPENAK / REVISIONES					
AHOLKULARIA / CONSULTOR			INGENIARI EGILEA INGENIERO AUTOR		
CAF			TURNKEY ENGINEERING		
AHOLKULARIAREN ERREFERENTZIA REFERENCIA CONSULTOR			ERREFERENTZIA REFERENCIA		
TTE-IS-23001-DRW-0152			2RVA-IE-22-152-A		

OHARRAK :
NOTAS :

Número de cable / Tipo																					
Bornero +A20.C1-XA1	Conexión	2	4	6	8	1	3	2	4												
	Destino																				
	Puentes																				
	Número	1R	1S	1T	1N	1-4F	1-4N	1-5F	1-5N												
	Conexión					404F	404N	5	6												
	Destino	T-630KVA				+A6.C1-XA1				+A1.C1-XA1											

Número de cable / Tipo																			
- F1	0,6/1kV Cu 3[2(1x240)]+2(1x240)	R	S	T	N														
- FS404	0,6/1kV Cu 2x2,5+T					F	N												
- F1-5	0,6/1kV Cu 2x2,5+T							F	N										

A	PRIMERA EMISIÓN	MAR. 23	IAA	ETS
REV.	CLASE DE MODIFICACION	FECHA	NOMBRE	COMP. OBRA
BERRIKUSPENAK / REVISIONES				
AHOLKULARIA / CONSULTOR		INGENIARI EGILEA INGENIERO AUTOR		
				
AHOLKULARIAREN ERREFERENTZIA REFERENCIA CONSULTOR		ERREFERENTZIA REFERENCIA		
TTE-IS-23001-DRW-0153		2RVA-IE-22-153-A		

Número de cable / Tipo																													
Bornero +A20.C1 - XC1	Conexión	13	14	13	14	13	14	11	14	24	21	13	14	13	14	44	41	34	31	14	11	3	4	11	14				
	Destino	K27-2	K27-2		SML1		SMR1		KA-SD1		Q1		SA-Q1		SC-Q1		RHU		RHU		RHU		T2		Q1-7				
	Puentes	●		●		●		●		●		●		●		●		●		●		●		●					
	Número	1	2	3	4	5	6	7	8	9	10	11	12	13	14	15	16	17	18	19	20	21	22	23	24				
	Conexión	C-	C12		C22		C32		C42		C52		C62		C72		C82		C92		C102		C112		C122				
	Destino	+A5.U5-XME8	+A5.U5-XME8		+A5.U5-XME8		+A5.U5-XME8		+A5.U5-XME8		+A5.U5-XME8		+A5.U5-XME8		+A5.U5-XME8		+A5.U5-XME8		+A5.U5-XME8		+A5.U5-XME8		+A5.U5-XME8		+A5.U5-XME8				
	Número de cable / Tipo																												
	- W02E80C	0,3/0,5kV+P 24x1,5+P	1	2	3	4	5	6	7	8	9	10	11	12	13														
	- W02S13C	0,3/0,5kV+P 12x1,5+P														1	2	3	4	5	6	7							

OHARRAK :
NOTAS :

REV.	A	PRIMERA EMISIÓN	MAR. 23	IAA	ETS
		CLASE DE MODIFICACION	FECHA	NOMBRE	COMP. OBRA

BERRIKUSPENAK / REVISIONES

AHOLKULARIA / CONSULTOR	INGENIARI EGILEA INGENIERO AUTOR
 TURNKEY ENGINEERING	
<small>IKER AZPIURU ARAGON - Nº COL. 1999</small>	

AHOLKULARIAREN ERREFERENTZIA REFERENCIA CONSULTOR	ERREFERENTZIA REFERENCIA
------------------------------------------------------	-----------------------------

TTE-IS-23001-DRW-0154 2RVA-IE-22-154-A

1

2

3

4

5

6

7

8

9

10

OHARRAK :
NOTAS :

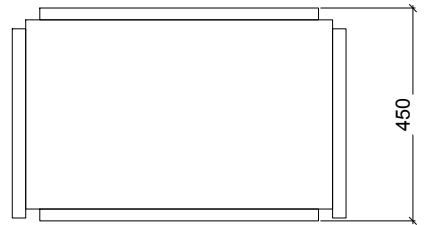
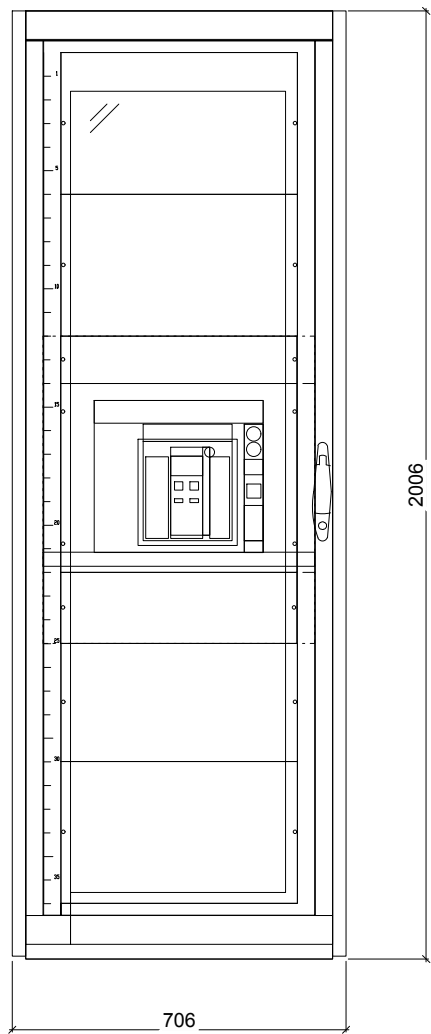

REV.	CLASE DE MODIFICACION	FECHA	NOMBRE	COMP.	OBRA
A	PRIMERA EMISION	MAR. 23	IAA	ETS	

BERRIKUSPENAK / REVISIONES

AHOLKULARIA / CONSULTOR	INGENIARI EGILEA INGENIERO AUTOR
CAF TURNKEY ENGINEERING	
	IKER AIZPURU ARAGON - Nº COL. 1999

AHOLKULARIAREN ERREFERENTZIA REFERENCIA CONSULTOR	ERREFERENTZIA REFERENCIA
------------------------------------------------------	-----------------------------

TTE-IS-23001-DRW-0155	2RVA-IE-22-155-A
-----------------------	------------------